

atop

A-A14 Assembled Manual

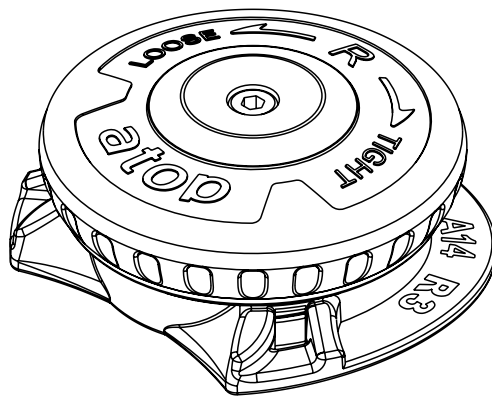

www.atop-team.com

1. Thread the wire lace into the holes of the base

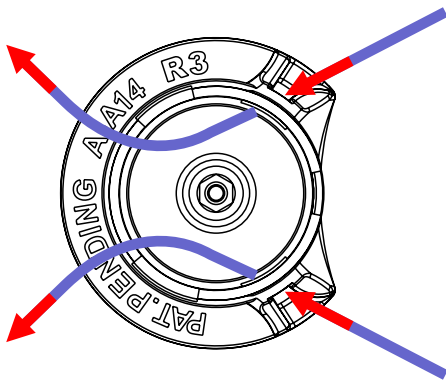

2. Thread the wire lace into the reel holes in the order of hole 1 → hole 2 → hole 3

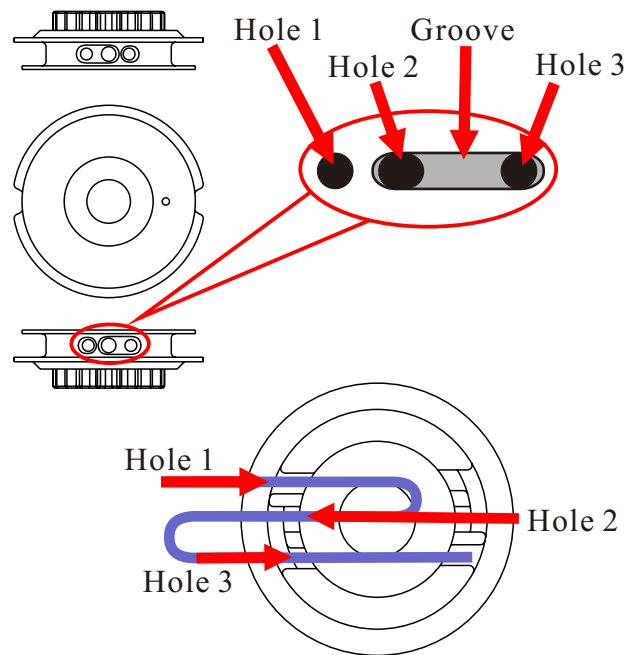

3. Tighten the wire lace to be fixed it

- ~1. Press the end of lace and tighten the wire lace which between hole 3 and hole 2. (See figure A)
- ~2. Take the end of wire lace across the middle part of wire lace, then conceal from the first wire lace (See figure B). Pull wire lace outward from hole 1, and keep 1mm distance away from the hole 1, and cut the rest of wire lace. (See figure C)
- ~3. Pull tightly outward from hole 1 and make sure the wire lace is out of the central of circle (See figure D), please check it is in accurate location. (See figure E)
- ~4. Repeat the above steps to fasten the other side of wire lace. (See figure F)

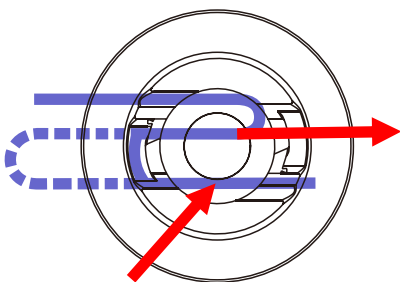

Press the wire lace at this point by your finger.
(figure A)

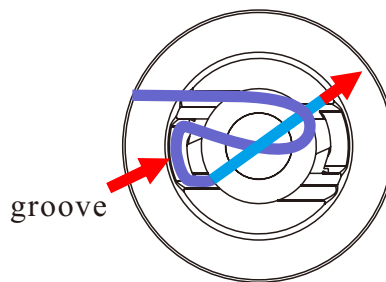

(figure B)

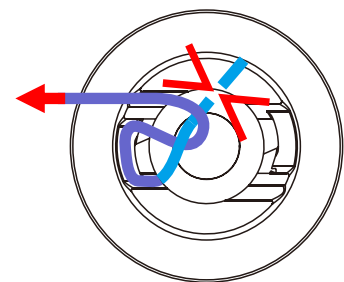

(figure C)

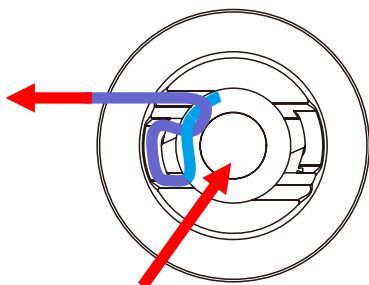

The central of circle
(figure D)

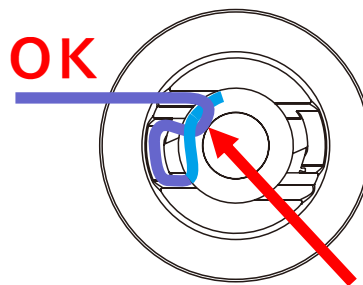

Make sure the wire lace is out of the central of circle.
(figure E)

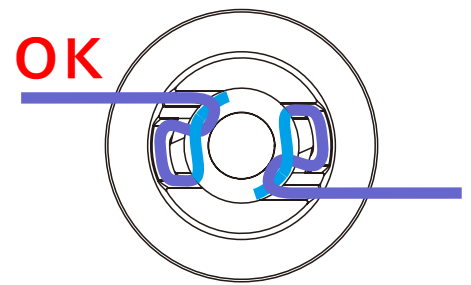

(figure F)

4. Put the reel into the base

~1. Pull the lace toward outside and put the reel into the base.

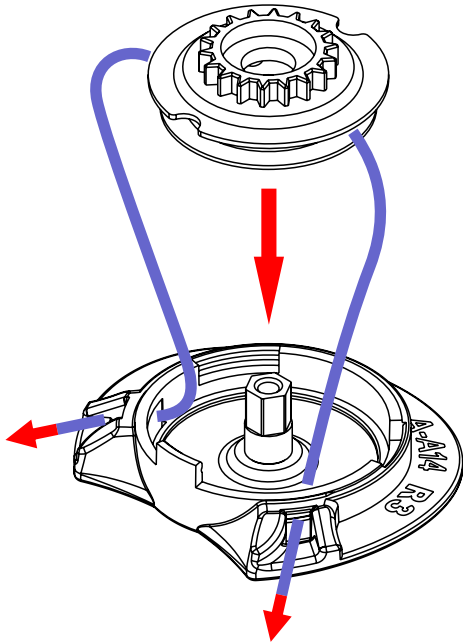

5. Inset the ratch

~1. Put the ratch's breach to aim at the bulge of the base.

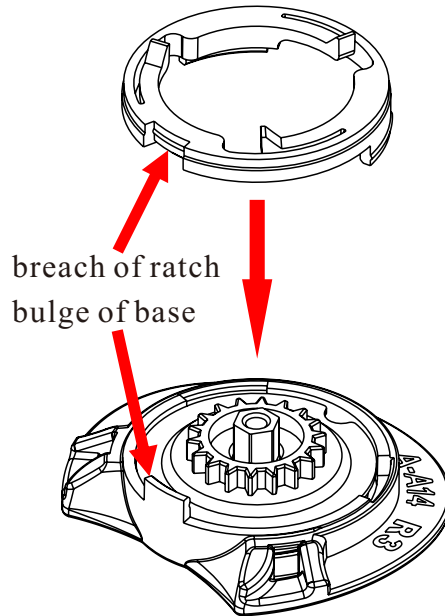

6. Inset the knob

~1. Please check the L/R knob is settled on the correct shoes. The left and right knob can't be exchanged.
~2. Under the knob has a hexagonal hole which has to aim at the hexagonal cylinder of base, and inset the knob into the base.

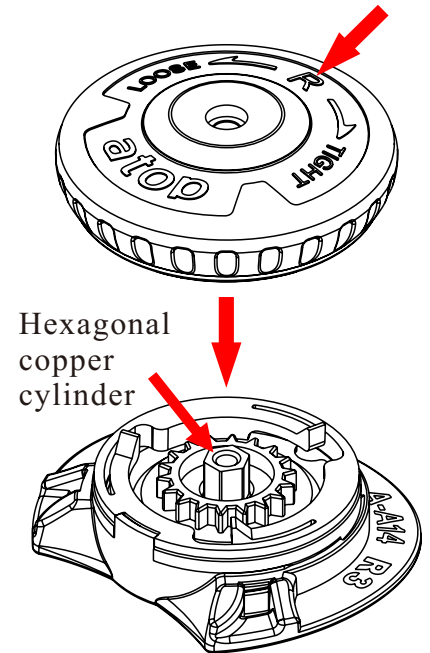

7. Fix the knob

~1. Setting the torque wrench on 2.5 kg, and fasten the screw. Please must make sure the screw is fastened in vertically.

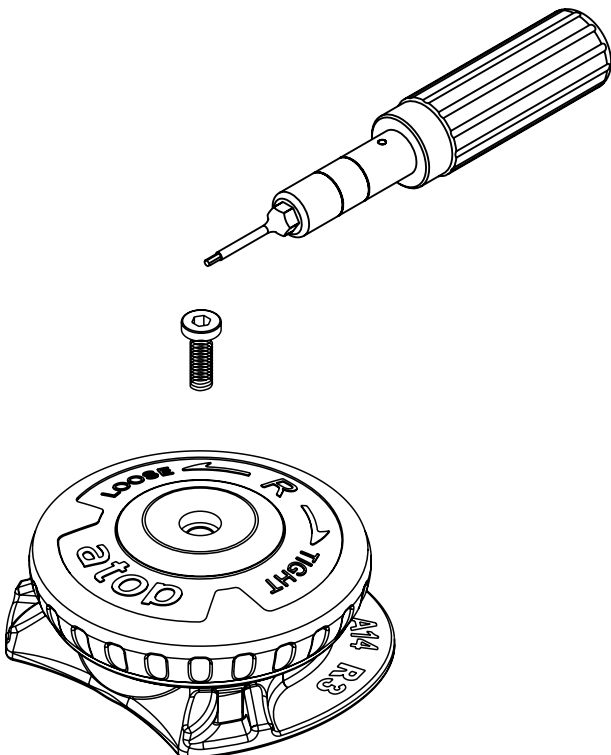

8. Testing

~1. Tighten the wire lace in clockwise.
~2. Release the wire lace in anticlockwise.
~3. Pull out the wire lace inside the base.
~Repeat the above steps three times, as you tighten and release the wire lace which runs smoothly, then it is assembled well.

